

OLYMPUS®

Your Vision, Our Future

MOTORIZED ILLUMINATION WITH
POWER FOCUS

BXFM-A

*Higher efficiency through PC control.
Motorized illuminator with
power focusing capability.*



The BXFM-A offers the ideal compact module of automated optical microscopic inspection and high power motorized focusing for the integration into various optical inspection systems.

Every system manufacturer wants the best possible optical system — one whose quality and flexibility provide superior performance in a wide variety of applications. To answer that need in a way that meets the highly specific requirements of system manufacturer in such

diverse fields as inspection and production, Olympus presents today's most effective solution:

The BXFM-A motorized illuminator with power focus & the UIS Infinity-corrected Optical System

UIS
UNIVERSAL
INFINITY SYSTEM



Setting example 1:
BXM-A-F+U-D6REM+
objective lens+U-LH100-3 +
U-TR30-2+eyepieces



Setting example 2:
BXM-A-F+U-AFA1M+U-LH100-3+
U-D6REM+objective lens+U-TLU+
U-TV0.5XC+video camera

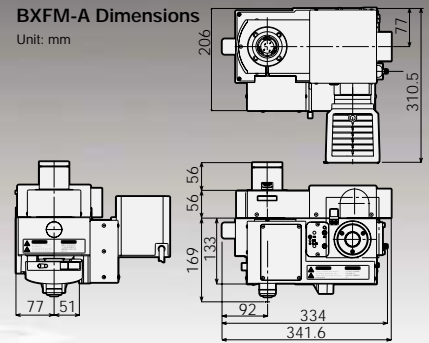

Features

- Compact unit which integrates a power focus function into the motorized reflected light illuminator.
- PC control of focusing, exchanges between brightfield and darkfield observation, aperture, and light intensity control. Allows appropriate observation setting for individual applications.
- Provides auto focus unit as an option. PC control programs are easy to make, using Olympus modules such as motorized filter wheels.
- Employs UIS optical system, renowned for providing high resolution and contrast in semiconductor inspections.
- Integrated motorized mechanism for the revolving nosepieces which comply with clean class 10< can be selected.
- Binocular, trinocular and single port tubes can be selected.
- Various adapters available, to comply with different types of video cameras and digital recording systems.

- Beside the standard halogen light source, it is possible to select optional high-intensity light source* or long life metal halide light source.*
- Semi-auto motorized microscope controls (via hand switch and focus dial adjustment knob unit**) are provided close to operator's hand.
- Mounting surfaces are provided on the left side and bottom side of the unit.

* In these cases, light intensity cannot be controlled.

** According to user preference: These modules are not required when a PC is used to control all operations.

Specifications

Focusing part	Stroke	Full stroke range (incl. retract range) : 7mm, Active stroke : 5mm
	Resolution	0.01 μ m
	Max. speed	5mm/sec (default 3mm/sec)
Illumination part	Observation Mode	Visible light reflected brightfield(BF)/darkfield(DF)
	Change mode	Motorized dedicated BF/DF cube switchover
	Motorized Aperture iris	Opening/closing with four shutter blades Motorized control using a stepping motor Centering and locking possible
	Field iris	Manual knob opening/closing Centering possible
	Filter cassette	Up to two filters, manual knob IN/OUT Filter size: 32mm diameter
Attachable unit	Light source	12V100W Halogen (standard) High intensity light source is optional
	Nosepiece	U-D6REM/D6REM/P5REM (for BF) U-D5BDREM/D5BDREM (for BF/DF)
	Controller	BX-UCB (Control box) U-ZPCB2* (Focus control board)
	Auto focus	U-AFA1M: Active laser method Applicable objective magnification 5X - 150X
	Observation tube	Observation/tube lens for UIS optics
	Objective lens	Reflected UIS objective lens
	Filter turret	U-FWR: Sextuple filter turret (Light source side) Filter size: 25mm diameter or 32mm diameter
	Controller	PC control via RS232C Command or Stand-alone control via Hand Switch and focus adjustment knob unit (U-HSTR2 & U-FH)
	Mounting surface	Six-screw fixation on left side and/or bottom of the body Screw hole 6-M8 10mm Depth
	Dimensions/Weight	206mm(W) X 133mm(H) X 334(D)mm/7.6Kg (BXM-A-F only)

*Only for motorized focusing method (BX-UCB is needed)

- OLYMPUS CORPORATION obtains ISO9001/ISO14001.

Specifications are subject to change without any obligation on the part of the manufacturer.

BXM-A System Diagram

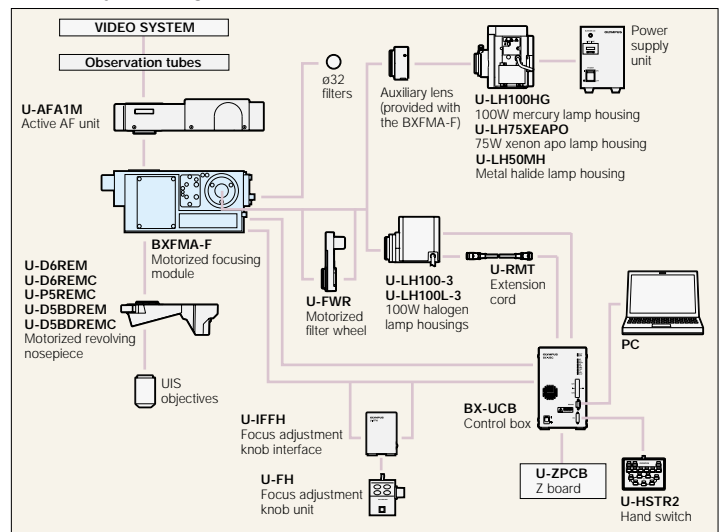

OLYMPUS[®]

OLYMPUS CORPORATION
Shinjuku Monolith, 3-1, Nishi Shinjuku 2-chome, Shinjuku-ku, Tokyo, Japan
OLYMPUS LIFE AND MATERIAL SCIENCE EUROPA GMBH
Postfach 10 49 08, 20034, Hamburg, Germany
OLYMPUS SURGICAL & INDUSTRIAL AMERICA INC.
One Corporate Drive, Orangeburg, NY 10962, U.S.A.

www.olympus.com

Printed in Japan M159E-0806B